

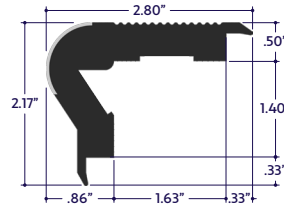

READ ENTIRE GUIDE BEFORE STARTING INSTALLATION

Important Notice: Verify correct luminaire was received with correct color temperature, voltage, and wattage before cutting or installing. ALUZ will not be responsible if incorrect luminaire is installed.

END VIEW / DIMENSIONS



GENERAL FEATURES

Applications	Carpeted Steps
Length	Built to Order (+/- 0.25" Tolerance)
Construction	Vinyl Extrusion
Finish	Matte Black
Driver	Remote (Sold Separately)
Weight	0.78 lbs per foot
Mounting	Adhesive
Listing	Dry Location Only UL2108, CSA C22.2 #9 UL8750, CSA250
Temperature Ratings	Operating / Startup: -20° to 48°C (-4° to 120°F) Storage: -40° to 76°C (-40° to 170°F)
Installation Link	

ELECTRICAL

Dimming	0-10V, Forward / Reverse Phase, Lutron, DMX, DALI
Wiring	Parallel
Socket	Custom
Maximum Lamps (Class 1 Applications)	432
Maximum Lamps (Class 2 Applications)	344
Luminaire Voltage	24VDC

PRODUCT INFORMATION

- Step extrusion for step lighting
- 24 Volts DC for easy and safe installation
- Choose from a variety of LED colors and whites
- Available in a variety of spacing (4", 6", 12", or custom spacing)
- Indoor installations are field cuttable
- Can be ordered to specific lengths longer than 4" for easier installation
- Available with raceway and end caps

MOUNTING OPTION

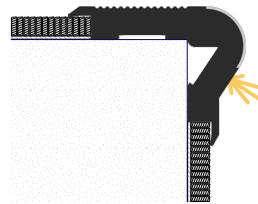

Carpeted Steps

Do not install on top of carpet. Install directly onto concrete or wood floor.

ELECTRICAL REQUIREMENTS

- Luminaires require a 24 Volt DC remote driver.
- To calculate driver size, determine Watts per Foot.
Example: 4" Spacing = 0.75W per Foot
- Determine Length in Feet.
Example: 60'
- Calculate Load: Multiply Watts per Foot x Length in Feet
Example: 0.75W x 60' = 45W
- Choose a driver from catalog.
Example: 30 Watt Driver
- Determine maximum distance using Maximum Wire Length Table on driver page.
Example: 45 watts is between 40W and 60W. Using #14 wire, maximum distance is 37' from driver to first LED

INSTALLATION TOOLS REQUIRED

- Electric Hammer Drill
- 14.4 to 28 Volt Cordless Drill
- Phillips Bits
- Utility Knife
- Electrical Cord
- Marker
- Wire Stripper
- Long Nose Pliers
- Drill Bits - Concrete or Wood
- Electrical Three Ways
- Safety Glasses
- Measuring Tape
- Laser Line or Chalk Line

WARNING

When using luminaires for any application, basic safety precautions should always be followed to reduce the risk of fire, electric shock, and personal injury. Luminaires must be installed in accordance with the NEC or CEC as applicable. ALUZ will not be responsible for any damage or malfunction caused by the following:

- Ensure power is off before installation begins, during replacements, additions, or repairs.
- Do not use LED Lighting if damaged, such as broken boards, loose connections, or frayed wire insulation. Inspect before installing.
- Do not install LED Lighting in hazardous locations.
- Do not cover LED Lighting with any material, as it may cause LEDs to overheat, melt, or ignite. (Fig. 1)
- Do not paint on or over fixture lens or LEDs. Paint or any other substance on lens or LEDs will cause a shift in color temperature.
- Soffit must be evenly painted with a neutral white to avoid color shift.
- Do not modify LED Lighting in the field.
- Do not overlap LED Lightstrips in any way.
- Only use LED Lighting with specified rated voltages. Do not exceed the specified voltage for any LED Lighting fixture.
- Do not use LED Lighting mounting channel as a raceway for additional wire. Non-factory feed through wires inside LED Lighting will void warranty.
- Ground Fault Circuit Interrupter (GFCI) protections should be provided on circuits or outlets when LED Lighting is used for outdoor applications.
- Surge protector must be set up for electrical power system to avoid damaging LED Lighting system.
- Do not make wiring connections without confirming provided wiring diagrams.
- Do not cut wires while the lighting is energized.
- Do not bend extrusion past permitted bend radius.
- Do not connect LED Lightstrip to power source while spooled or coiled. (Fig. 2)
- Do not connect DC output from remote drivers in parallel. Parallel connections interfere with dimming capabilities and result in feedback that damages drivers. (Fig. 3)
- Do not exceed maximum run lengths.
- Do not mount LED Lightstrip with staples, nails, or like means that might damage the insulation. Mount with double-sided tape and mounting clips.
- Do not penetrate LED Lightstrip with any foreign object. (Fig. 4)
- Do not mount inside tanks or enclosures of any kind.
- Do not force luminaire into a space that is too small.
- Do not submerge luminaires in any liquid. (Fig. 5)
- Do not install in any area that is continuously exposed to flowing or pooling water, such as underneath drain pipes, sprinklers, fountains, misters, etc.
- Do not cut, puncture, or penetrate the lighting's housing, end caps, or lens covers.
- Do not drop, bang, or rest weight upon lighting.
- Do not apply excessive pressure to any part of LED Lighting or LEDs. (Fig. 6)
- Do not bend LED Lighting power cord or continuous connector past permitted bend radius. Bending past permitted bend radius will break the seal of the cordgrip or damage the insulation. 1.5" minimum bend radius.
- Do not install LED Lightstrip in a zig zag fashion. (Fig. 7)
- Do not fold, crease, or twist LED Lightstrip. (Fig. 8)
- Do not bend LED Lightstrip along a horizontal plane.
- Do not overlap LED Lightstrip at any location. (Fig. 9)
- Do not cross or overlap mounting channels and twist lightstrip to overlap. (Fig. 10)
- Do not install LED Lighting in places where the power cord is subject to continuous flexing.
- Do not twist continuous connector, power cord, or any other wiring.
- Do not hold, carry, or suspend LED Lighting by the power cord.

FIGURES

Fig. 1

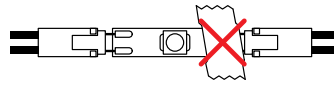

Fig. 2

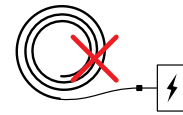

Fig. 3

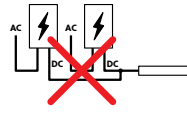

Fig. 4

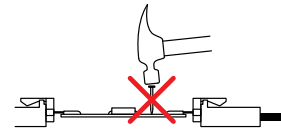

Fig. 5



Fig. 6

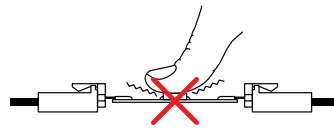

Fig. 7

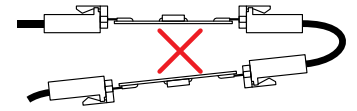

Fig. 8

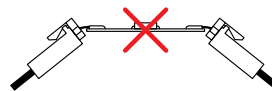

Fig. 9

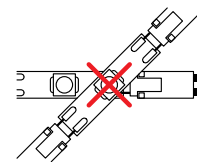
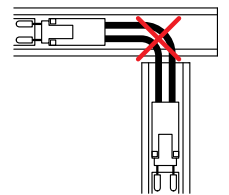

Fig. 10



CLEANING MATERIALS

The use of solvents and/or cleaners which are not compatible with polycarbonate will result in the softening, crazing, and/or cracking of the plastic part. This is especially true of polycarbonate lamps and mounting bases which may be under stress in their normal applications.

COMPATIBLE WITH POLYCARBONATE

- | | |
|-----------------------|--------------------------|
| • Mild soap and water | • 2% Sol. Reg. Joy |
| • Mineral Spirits | • 10% Sol Bon Ami |
| • Isobutyl Alcohol | • White Kerosene |
| • VM and P Naphtha | • Methyl Alcohol |
| • Varsol No.2 | • Heptane |
| • Mexane | • Petroleum Ether / 65°C |
| • Freone TF and TE-35 | • Isopropyl Alcohol |
| • Ethanol | • Lacryl PCL-2035 |
| • Dirtex | • Polycarbonate Cleaner |

NOT COMPATIBLE WITH POLYCARBONATE

- | | |
|------------------------------|------------------------------|
| • Trichlor | • Liquid Cleaner - 8211 |
| • Gasoline | • Toluol |
| • Liquid Detergents | • Agitene |
| • Acetone | • Benzol |
| • Carbon Tetrachloride | • Ajax |
| • Pink Lux (Phosphate free) | • Kleenol Plastics |
| • Triclene | • Lysol |
| • Chlorinated Hydrocarbons | • Stanisol Naphtha |
| • #1 & #3 Denatured Alcohol | • Oils |
| • Methyl Ethyl Keytone (MEK) | • Lemon Joy (phosphate free) |
| • Texize-8006, 8129, 8758 | • Diversol |
| • MIBK | • Lestoil |

FORWARD / REVERSE PHASE DIMMING (PH)

Technical Requirements For Control Equipment

- Magnetic Low Voltage (MLV): Magnetic (core and coil, toroidal) transformer-supplied low voltage lighting.
- Electrical Characteristic: Inductive
- Special Requirements: Symmetric cycles ($VDC \leq 2$), smooth turn off (positive and negative periods are equal for safe MLV transformer operation).
- Phase dimmers must be compatible with LED loads.

PHASE DIMMER RATINGS

The stated VA (volt-ampere) rating is the rated capacity of the dimmer which includes the magnetic transformer heat losses and the lamp load. A transformer dissipates less than 20% of the connected load as heat. The lamp load plus the transformer loss determine the dimmer capacity required. See the example below.

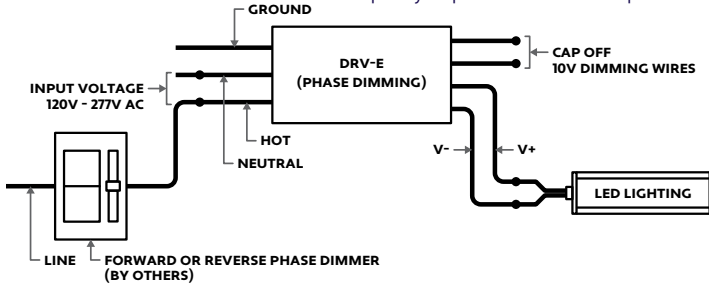

PHASE DIMMING WIRING DIAGRAM

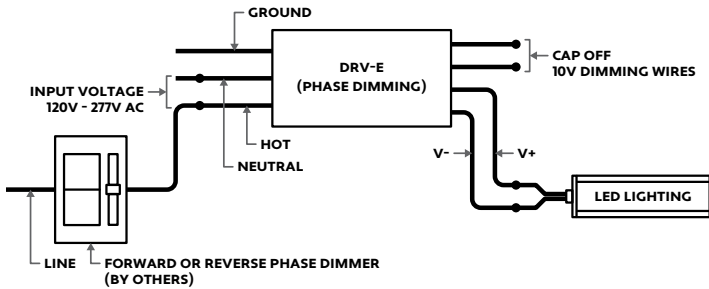

Notes: Wire colors vary based on model. See individual submittal for more information, or refer to wiring diagram on driver label. Confirm wire colors before connecting to power source. Cap off dimming wires individually for non-dimming applications. For best dimming performance, use a minimum load of 50% and a maximum load of 80%.

0-10V DIMMING (10V)

Technical Requirements For Control Equipment

- The light output of the LEDs operated by the controllable LED driver is controlled by DC voltage applied to the control input leads (gray and violet). The actual response curve of LED driver current versus control voltage.
- The control device must be capable of accepting or sinking the DC current flow from the driver. The DC current from the driver that must be sunk by the control circuit is approximately 150uA (+50% for isolated dim interfaces, up to 1.5mA for non isolated dim interfaces).
- If the control bus is opened, or if the control device internally opens the control bus under some conditions, the voltage on the control bus will then be a function of the drivers, which is 10-15V. Maximum light output will be delivered under this condition.
- If the control bus is shorted either by a mechanical switch in the control or by the circuitry of the control device, or inadvertently in the wiring, the current on the control bus will be less than 1.5mA.
- As can be determined from the two items, simple two-level operation of the drivers can be achieved by proper usage and application of a simple open/closed switch on the control bus with maximum light being achieved when the switch is open and minimum light with the switch is closed.
- The driver is intended to be used with control voltages between 0-10VDC volts peak maximum on the driver control leads.
- Control equipment intended to control more than one driver must be capable of sinking the current supplied to the control bus by the maximum number of drivers specified for the control device. At any given level setting it must maintain control bus voltage constant within a range of +/-5% as the number of drivers connected to the control bus varies from a minimum of one driver up to the maximum number specified for the control device.
- Driver of various ratings may be mixed on the same control system.

0-10V DIMMER RATINGS

The stated VA (volt-ampere) rating is the rated capacity of the dimmer which includes the electronic transformer heat losses and the lamp load. A transformer dissipates less than 20% of the connected load as heat. The lamp load plus the transformer loss determine the dimmer capacity required. See the example below.

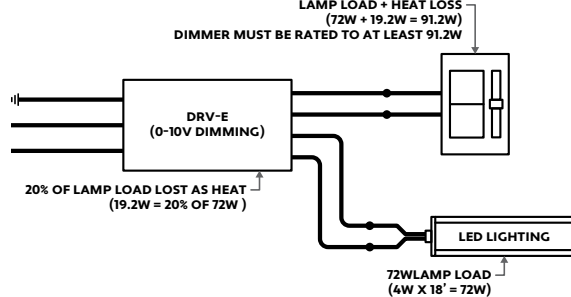

0-10V DIMMING WIRING DIAGRAM

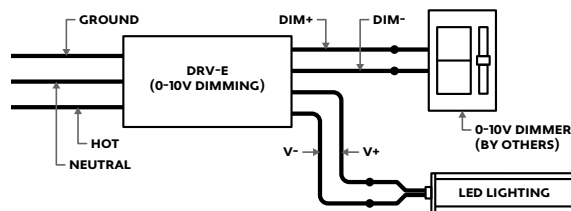

MAXIMUM RUN BASED ON 80% LOAD OF ELECTRONIC DRIVER MAXIMUM WATTAGE

Driver Wattage	80% Load	1.5W Max Run	2W Max Run	2.5W Max Run	3W Max Run	3.6W Max Run	4W Max Run	4.5W Max Run	5W Max Run	5.5W Max Run	6W Max Run	6.5W Max Run
30	24W	16'	12'	9.6'	8'	6.6'	6'	5.3'	4.8'	4.36'	4'	3.69'
60	48W	32'	24'	19.2'	16'	13.3'	12'	10.6'	9.6'	8.7'	8'	7.3'
96	76.8W	51.2'	38.4'	30.7'	25.6'	21.3'	19.2'	17.1'	15.36'	13.9'	12.8'	11.8'
150	120W	80'	60'	48'	40'	33.3'	30'	26.6'	24'	21.8'	20'	18.4'
200	160W	106.6'	80'	64'	53.3'	44.4'	40'	35.5'	32'	29'	26.6'	24.6'
300	240W	160'	120'	96'	80'	66.6'	60'	53.3'	48'	43.6'	40'	36.9'

Note: Maximum Run refers to the total length of lighting that can be connected to a single driver. Maximum Runs for individual products still apply.

MAXIMUM WIRE LENGTH TO PREVENT EXCESS VOLTAGE DROP

Wire Size	Load Wattage (W)													
	15	24	30	40	48	60	76	96	120	150	160	200	240	300
20 AWG	78'	49'	39'	31'	24'	19'	15'	12'	9'	7'	7'	5'	4'	3'
18 AWG	125'	78'	62'	49'	39'	31'	24'	19'	15'	12'	11'	9'	7'	6'
16 AWG	199'	124'	99'	78'	62'	49'	39'	31'	24'	19'	18'	14'	12'	9'
14 AWG	316'	197'	158'	125'	98'	79'	62'	49'	39'	31'	29'	23'	19'	15'
12 AWG	503'	314'	251'	199'	157'	125'	99'	78'	62'	50'	47'	37'	31'	25'
10 AWG	800'	500'	400'	316'	250'	200'	158'	125'	100'	80'	75'	60'	50'	40'
8 AWG	1273'	795'	636'	503'	397'	318'	251'	198'	159'	127'	119'	95'	79'	63'

MAXIMUM WIRING DISTANCE OF DRIVER TO LIGHTING

The maximum wiring distance of driver to LED Lighting refers to the wire used between the driver and first LED of the luminaire. If the wire gauge is inadequate for the wiring distance, the luminaire will receive decreased voltage, insufficient to power the LEDs. Refer to the table to determine appropriate wiring distances based on wire gauge and the LED load.



MOUNTING INSIDE AN ENCLOSURE

- Only mount drivers inside enclosures rated for your application
- Always ground drivers to enclosure
- Do not mount drivers without an enclosure
- Use enclosure knockouts and water-tight conduit fittings when applicable

DRIVER CARE

- Do not submerge drivers in any liquid
- Do not leave any exposed wires
- Do not cover driver without proper ventilation
- Do not install damaged driver
- Do not exceed maximum load

DIMMER TRIM VALUES

Set dimmer trim value as needed to prevent flickering and irregular dimming. Review dimmer specifications for trim value adjustment. Dimmers by others.

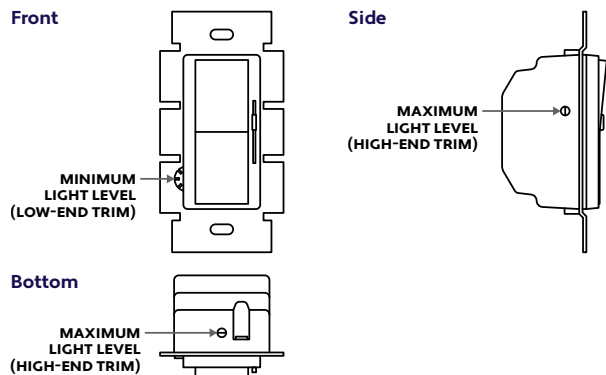

LUTRON HI-LUME 2-WIRE DIMMING (L7EA)

Technical Requirements For Control Equipment

- The Hi-lume 1% 2-Wire LED Driver (L7EA) is a high performance LED driver that provides a smooth, continuous, flicker-free 1% dimming for virtually any LED fixture. Primary voltage is 120V and secondary side is 12VDC or 24VDC. A rated life time of 50,000 hours @tc -149°F (65°C). Inrush current: < 2A. Minimum operating temperature ta = 32°F (0°C).
- Continuous, flicker-free dimming from 100% to 1%. Compatible with selected Maestro Wireless, RadioRA 2, HomeWorks QS, GRAFIK Eye QS, GRAFIK Systems, Quantum, and C-L Dimmers.
- The driver is California Title 24 JA8 Compliant.

Wiring Diagram for Controls Requiring Neutral (JA8 Compliant)

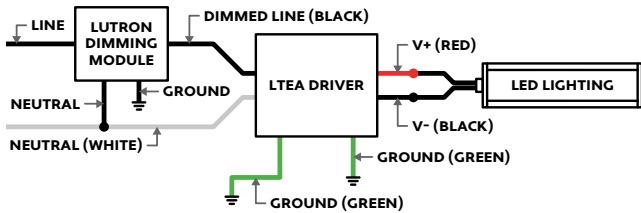

Wiring Diagram for Controls Not Requiring Neutral (JA8 Compliant)

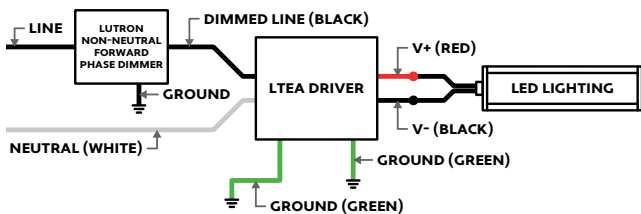

LUTRON HI-LUME 3-WIRE DIMMING (L3DA)

Technical Requirements For Control Equipment

- Hi-lume 1% EcoSystem/3-Wire Driver (L3DA) is a high-performance LED driver that provides smooth, continuous 1% dimming for virtually any LED fixture, primary voltage is 120-277 V~ at 50/60 Hz and secondary side is 12VDC or 24VDC. A rated life time of 50,000 hours @tc -149°F (65°C). Inrush current: < 2A. Minimum operating temperature ta = 32°F (0°C).
- Continuous, flicker-free dimming from 100% to 1%. Compatible with Energi Savr Node unit with EcoSystem, GRAFIK Eye QS control unit, PowPak dimming module with EcoSystem, and Quantum systems, allowing for integration into a planned or existing EcoSystem lighting control solution. Standard 3-wire, line-voltage phase control technology for consistent dimming performance.

Wiring Diagram for 3-Wire Controls

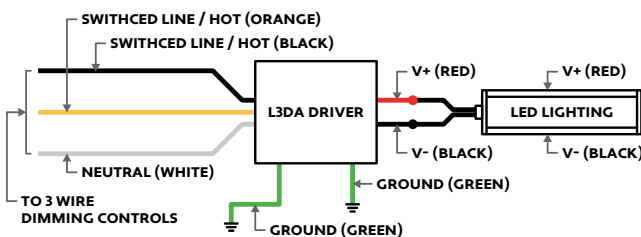

Wiring Diagram for EcoSystem Digital Controls

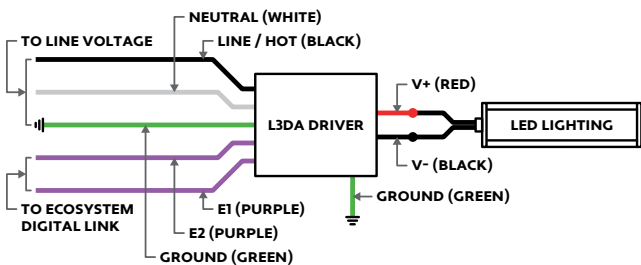

Note: Colors shown on wiring diagrams correspond to terminals on driver

LUTRON HI-LUME 3-WIRE PREMIER DIMMING (L3D0)

Technical Requirements For Control Equipment

- Hi-lume Premier 0.1% EcoSystem / 3 Wire constant voltage 24V LED driver with Soft-on, Fade-to-Black. The Hi-lume Premier 0.1% Constant Voltage Driver is a high-performance LED driver capable of controlling up to 96W of 24V constant voltage loads. This driver provides smooth and continuous dimming down to 0.1% low-end. It is ideal for use with strip lighting in applications such as coves, under or over cabinet lighting and pathway lighting. The driver is UL Listed with an integrated wiring compartment and can be mounted up to 150' away from the load.
- Continuous, flicker-free dimming from 100% to 0.1%
- Soft-on, Fade-to-Black operation for EcoSystem controls: fades smoothly between 0% and 0.1% when turned on and off for an incandescent like dimming experience.
- PWM dimming meets IEEE1789 over the entire dimming range.
- UL Listed for United States and Canada (cULus®).
- NOM certified for Mexico.
- Field Adjustment Knob offers customer low-end light output tuning for better fixture-to-fixture matching.
- Guaranteed dimming performance when used with Lutron controls:
 - HomeWorks QS, Energi Savr Node units with EcoSystem controls, GRAFIK Eye QS with EcoSystem controls, PowPak with EcoSystem dimming modules, PowPak with EcoSystem wireless fixture controls, and Quantum systems, allowing for integration into a planned or existing EcoSystem lighting control solution.
 - Lutron 3-wire controls and interfaces.
- Protected from miswires of input power, up to 277 V~, to EcoSystem control inputs.
- Rated lifetime of 50,000 hours at 40 °C (104 °F) ambient temperature and max load.
- FCC Part 15
 - Class A (277 V~)
 - Class B (120 V~)
- The driver is California Title 24 JA8 Compliant.

Wiring Diagram for 3-Wire Controls (JA8 Compliant)

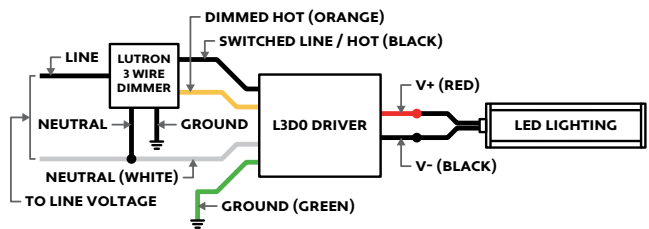

Wiring Diagram for EcoSystem Digital Controls (JA8 Compliant)

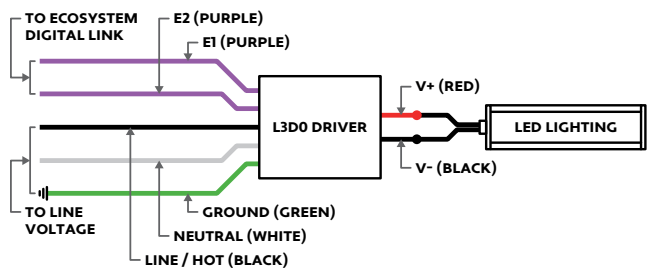
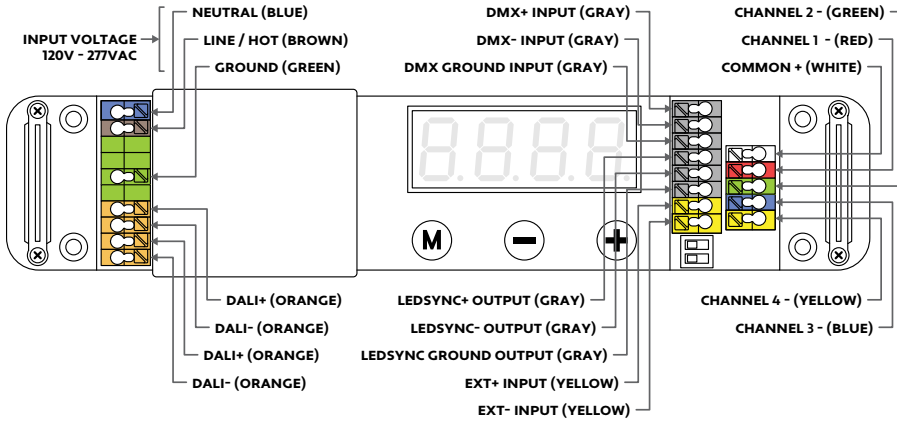
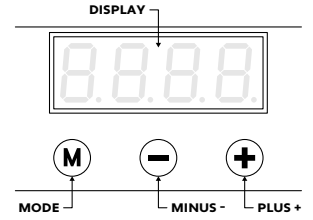

DIAGRAM OF DRIVER



DIGITAL INTERFACE



NOTES (DMX)

- Wire colors on diagram correspond to colors of driver terminals.
- Default DMX address of each luminaire is 001. Consult a third party DMX commissioner to modify at time of installation. ALUZ does not provide DMX commissioning.
- DMX Address must be set for each driver. Default DMX address is 001.
- A DMX Control System (by others) must be used to operate the lighting.
- The last driver in a daisy chain sequence must be terminated.
- Driver load not to exceed 100W.
- For best dimming performance, it is recommended to load drivers to a minimum of 50% (50W) and a maximum of 80% (80W).
- Up to 28 drivers may be daisy chained together using shielded cable specified for DMX wiring.
- Ensure DIP Switch 1 is set to ON (Left) to activate 24V operation.

DMX Wiring: Static White

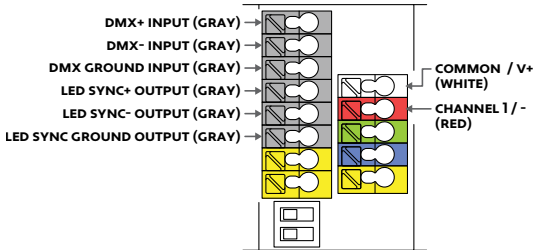

DMX Wiring: RGBW

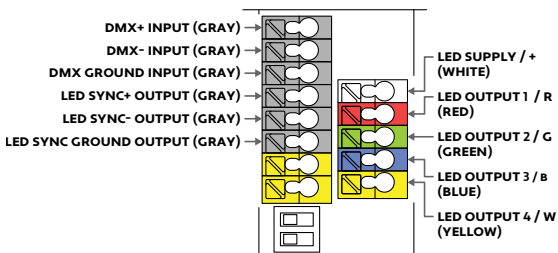

DMX Wiring: Dynamic White (DWH)

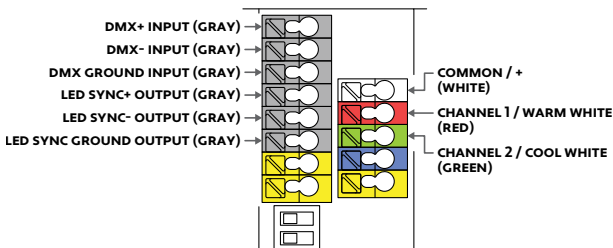

DMX Daisy Chain

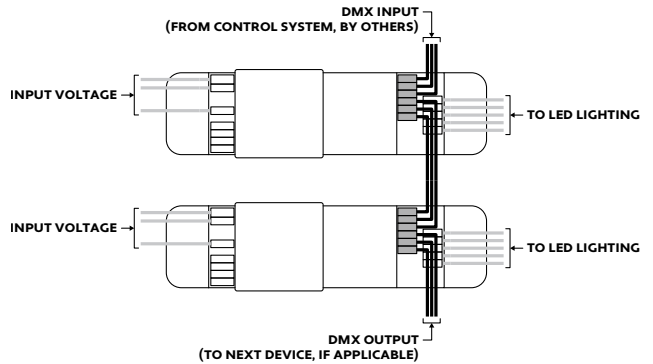

NOTES (DALI)

- Wire colors on diagram correspond to colors of driver terminals.
- DALI commissioning to be performed by a third party at time of installation. ALUZ does not provide DALI commissioning.
- DALI Address must be set for each driver.
- A DALI Control System (by others) must be used to operate the lighting.
- Driver load not to exceed 100W.
- For best dimming performance, it is recommended to load drivers to a minimum of 50% (50W) and a maximum of 80% (80W).
- Up to 28 drivers may be daisy chained together using shielded cable specified for DALI wiring.
- Ensure DIP Switch 1 is set to ON (Left) to activate 24V operation.

DALI Daisy Chain

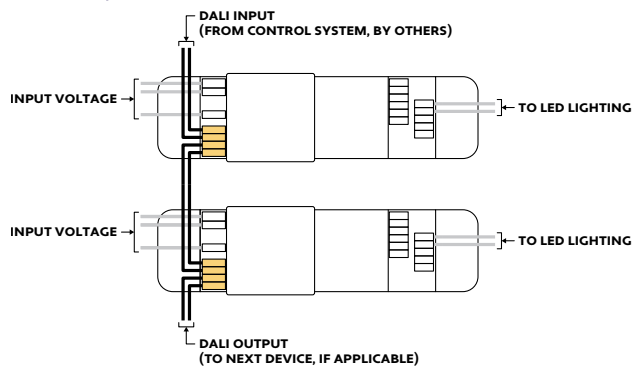

MODE OF OPERATION

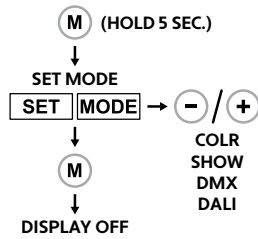

• Set Mode to DMX or DALI

SET LED GROUPS

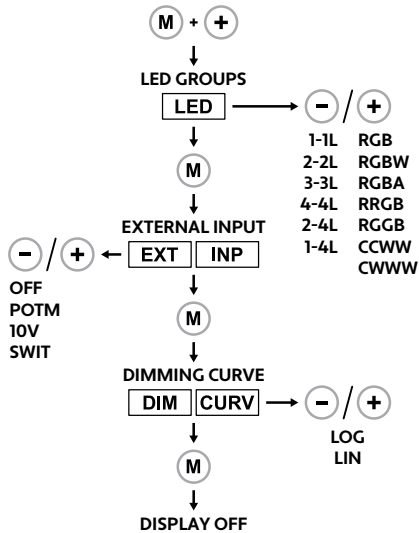

- Set LED Groups to RGBW for RGBW lighting.
- Set LED Groups to CCWW for Dynamic White lighting.
- Set External Input to OFF.
- Set Dimming Curve to Linear.

STANDALONE OPERATION (Network Operation)

Set DMX Address

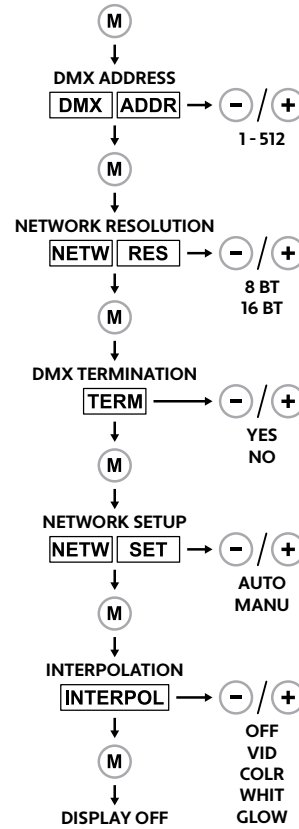

Set DALI Address

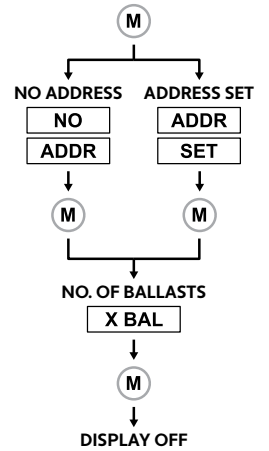

- Consult with a third-party DMX or DALI professional to determine which settings are best for your application. ALUZ does not provide DMX or DALI commissioning.

OTHER FUNCTIONS

Visual Test

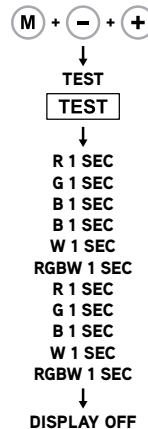

Reset Settings

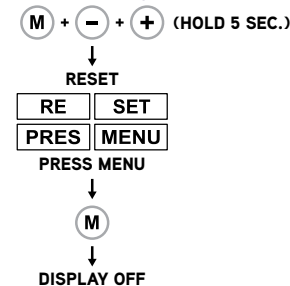

Lock Driver

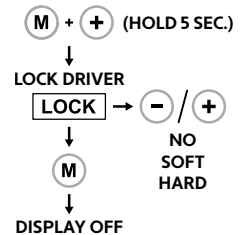

- Always perform the visual test function after wiring to ensure all channels are behaving appropriately.
- Reset driver to factory settings if necessary. It is recommended to reset each driver before adjusting settings for the first time.
- Lock driver if applicable (not recommended).

STANDALONE OPERATION (Color / Show)

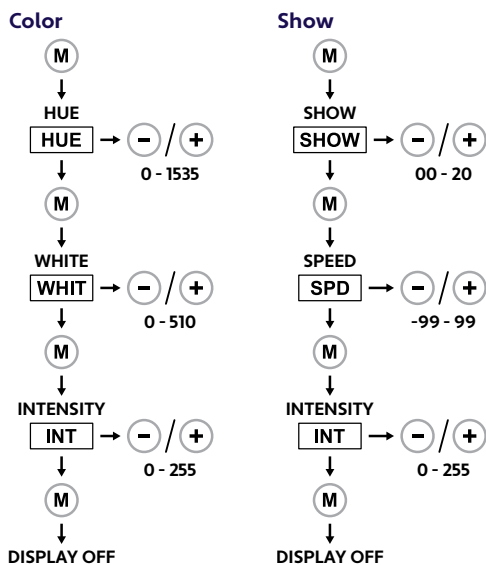

- Standalone Operation should only be used when a control system is not present to control the lighting (not recommended).

DESIGN GUIDELINES

Single Side Steps

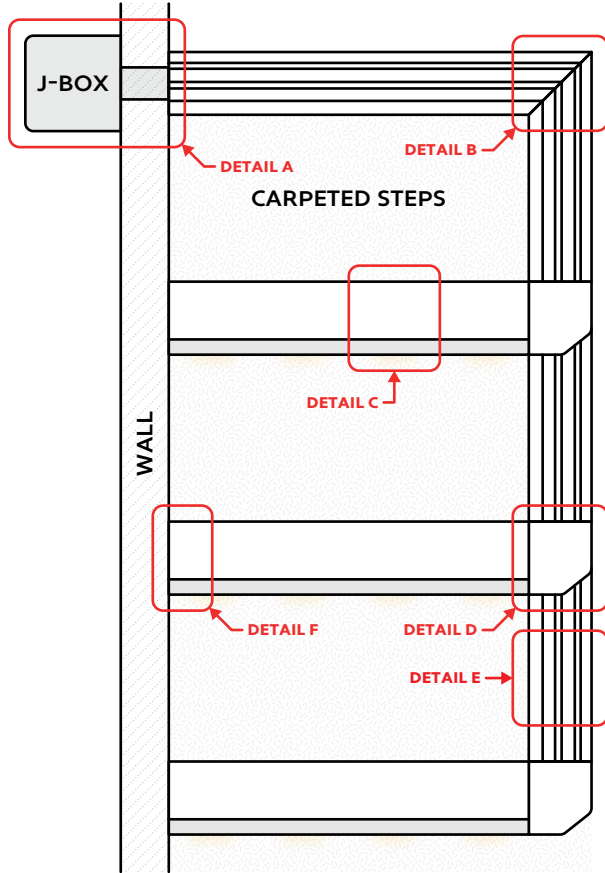

Dual Side Steps

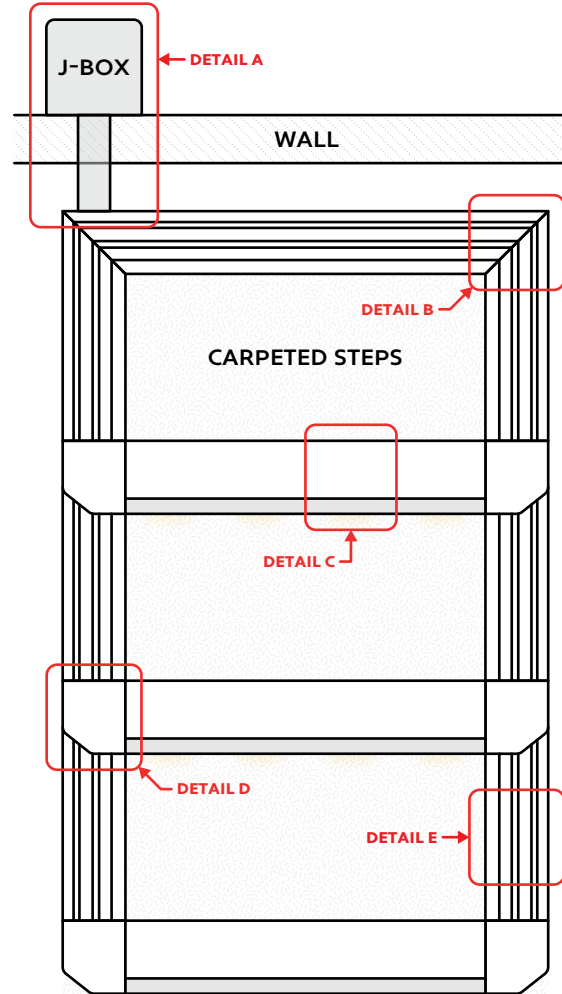

KEY

- Detail A** **Junction Box (By Others):** Wiring connection from junction box to raceway via conduit (by others).
- Detail B** **Raceway Mitering:** Luminaire segments are connected using an external continuous connector, with ends butted together.
- Detail C** **Step Extrusion:** Step extrusion with lights on bottom surface only.
- Detail D** **End Cap:** The end cap connects the step extrusion with riser and tread raceway on both sides of the step.
- Detail E** **Tread Raceway:** The raceway transitions from carpet to floor and is used to run wiring from step to step.
- Detail F** **Wall:** The step extrusion butts up to the wall on one side, and has an end cap on the other side.

Note: Drawings not to scale. Product may differ from examples shown.

APPLICATION GUIDELINES

- Follow the diagrams and steps below if applicable to your installation.
- LED lightstrip and modules require a team effort to ensure a secure and correct installation.
- Use a wire puller stand to prevent tangles, twists, and snags.

NOTE

- Extrusions are shipped in 8' segments
- Due to cut increment restrictions (+/- 0.25" Tolerance), lightstrip is shipped to the closest measurement ordered. The lightstrip must be centered inside the extrusion.

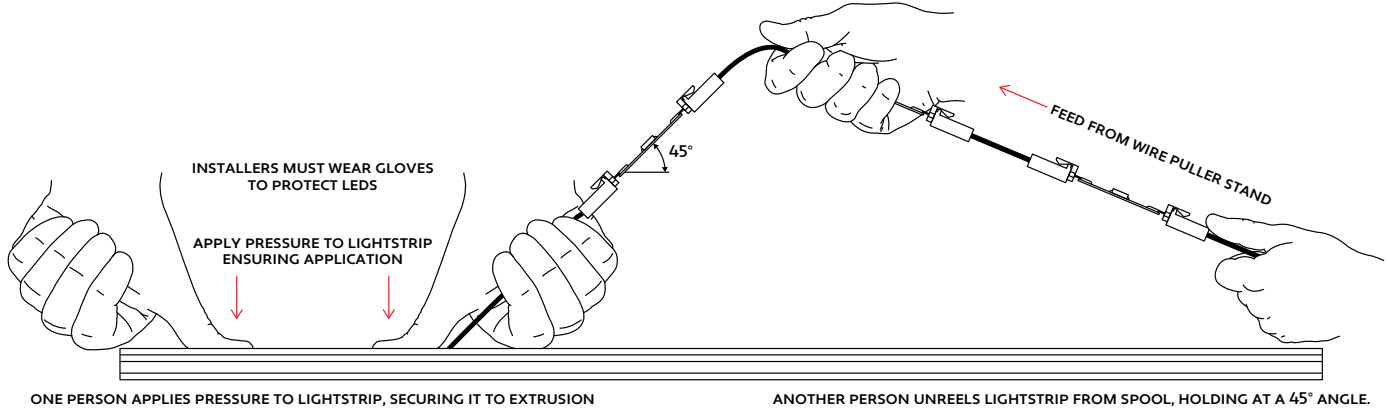

CONNECTORS

- 1 Size lightstrip to desired length. Disconnect female terminal with wires from PCB by gently lifting tab to release.
- 2 Insert power connector or continuous connector into male terminal. Ensure connector snaps into place.

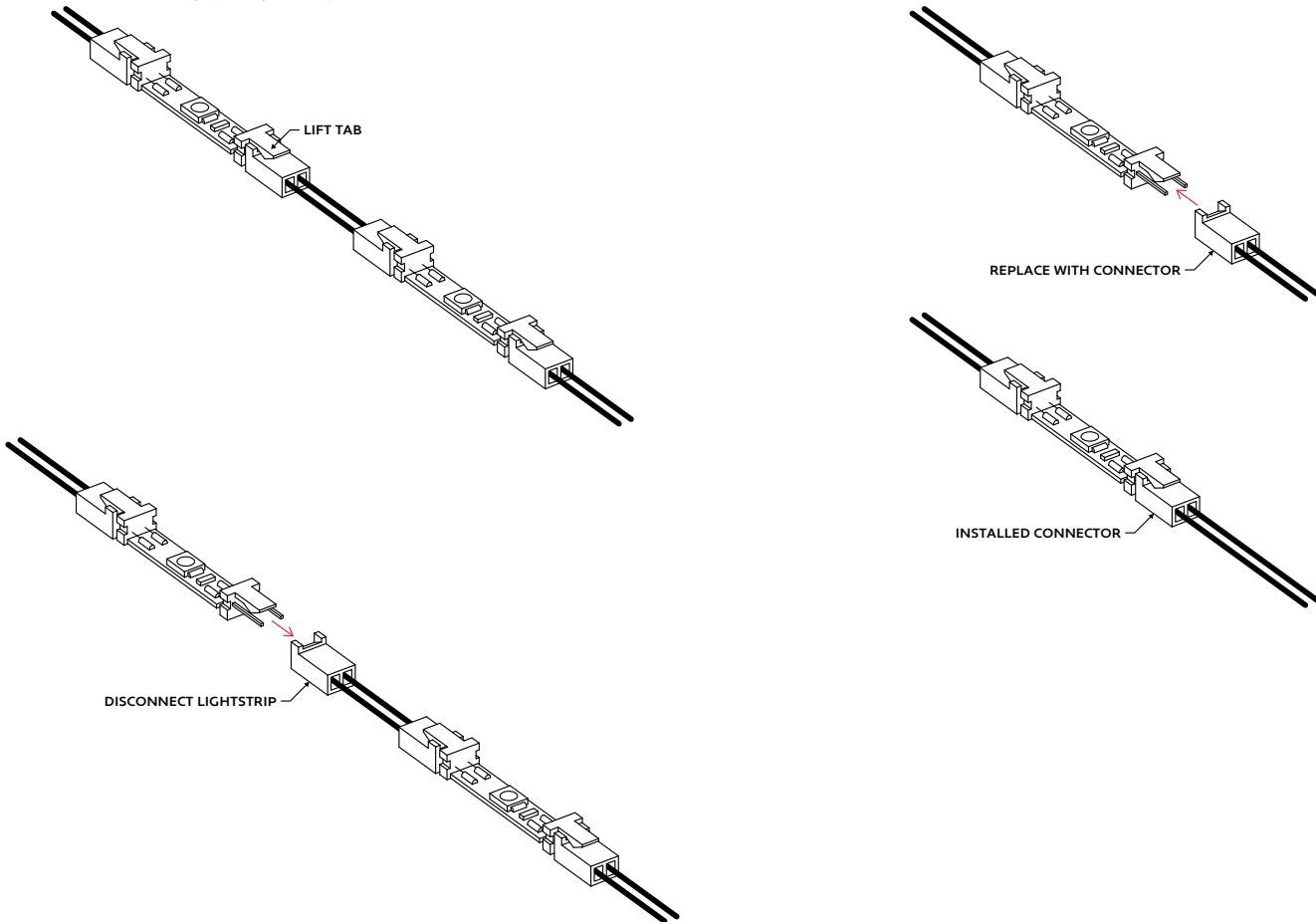

TYPICAL THEATRE LAYOUT

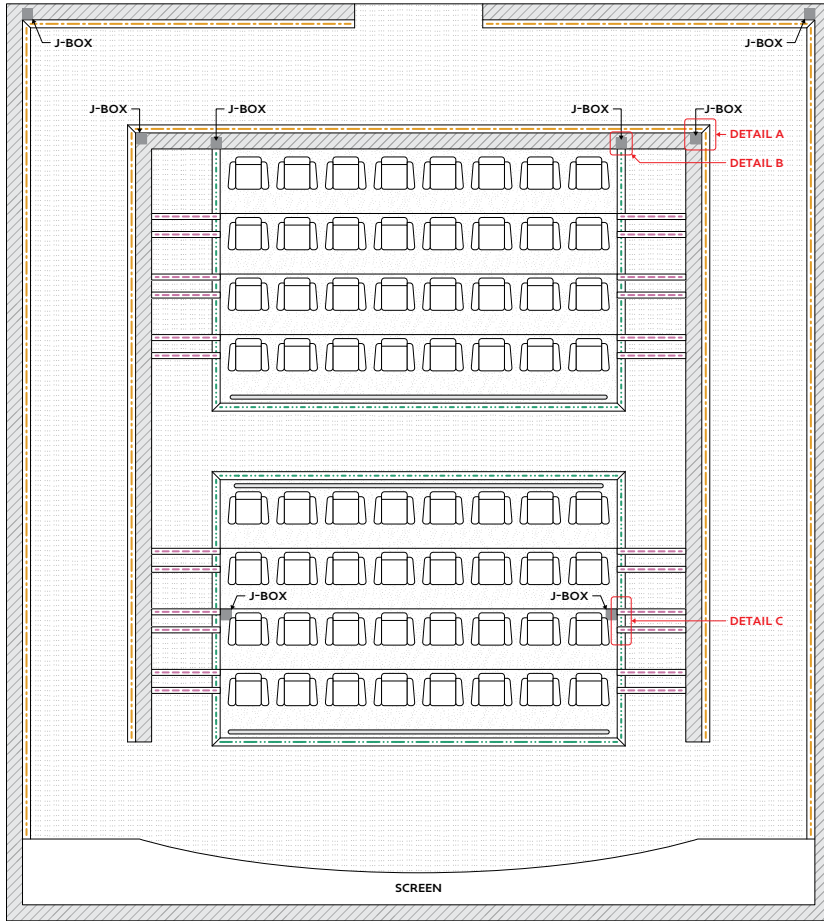

KEY

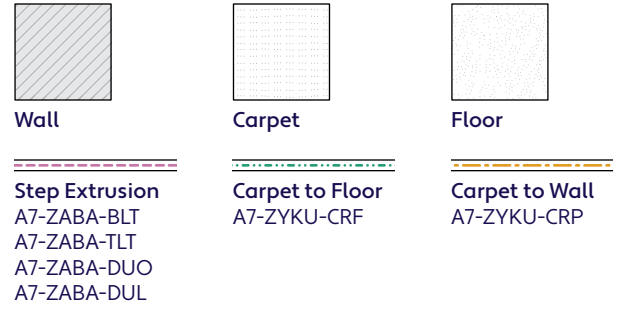

NOTES

- Install J-Boxes (by others) in locations where they will be best utilized.
- Use separate wires for each circuit.
- Do not use a common ground.
- Typically use 14 gauge stranded wire.
- Use separate wire colors to identify circuits.

DETAIL A

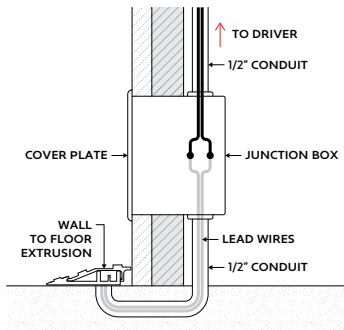

DETAIL B

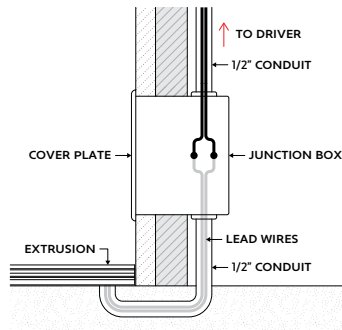

DETAIL C

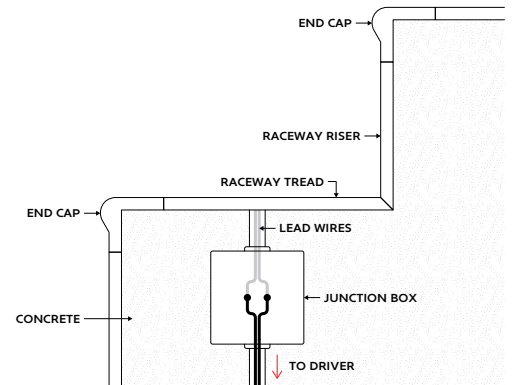
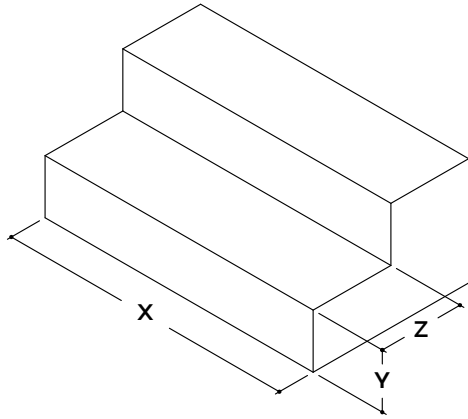
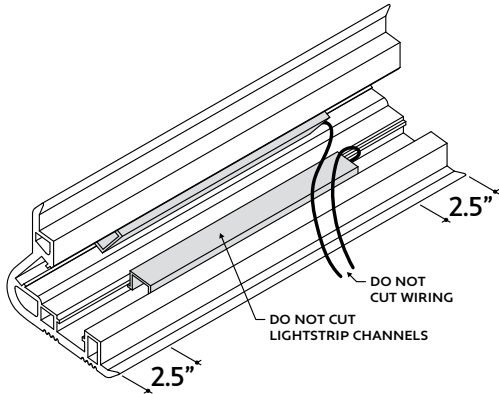

DIAGRAM OF STEPS



X: Tread Width
Y: Tread Height
Z: Tread Depth

- 1 Measure the Tread Width (X) of the treads where step extrusion will be installed. Subtract 2-1/2" from the X value to compensate for the width of 1 End Cap.
- 2 If applicable, cut up to 2-1/2" off one end of extrusion to create space for the End Cap. Place lighting bullnose down, then measure from end of extrusion and mark a cut line. Slowly cut with a miter saw to prevent tearing or rough edges.
Note: Do not cut lightstrip or wiring.



- 3 Apply a generous amount of adhesive to the underside of a clean, dry step extrusion. Apply step extrusion to clean, dry concrete or wood step free of dust and debris.
Note: Smooth out extrusion after placing to eliminate adhesive bumps and imperfections.

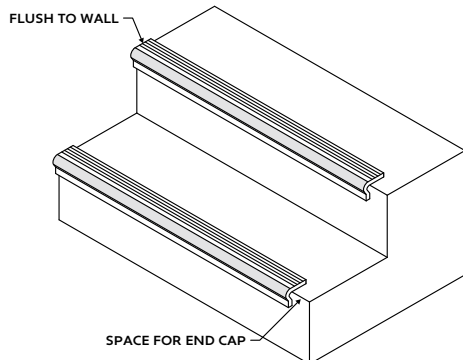

- 4 Measure the Tread Depth (Z) of the treads where the raceway will be installed. Subtract 2" from the Z value to compensate for the depth of the End Cap.
- 5 Miter the Tread Depth (Z) raceways where they will meet the Tread Height (Y) raceways. Apply a generous amount of adhesive to the underside of a clean, dry raceway base. Apply raceway base to clean, dry concrete or wood step. Secure raceway base with 3/16" x 1-1/4" flat head tapcon screws for concrete. Use wood screws for wood steps. Refer to Raceway Mitering Guidelines for additional details.
Note: Smooth out extrusion after placing to eliminate adhesive bumps and imperfections.

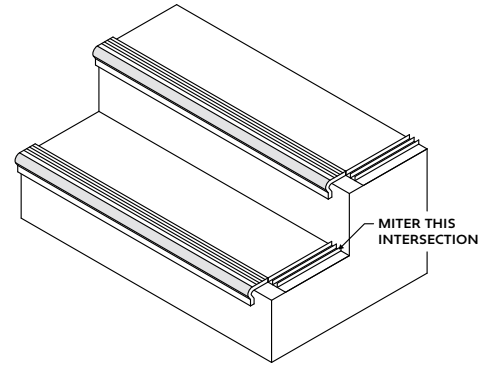

- 6 Measure the Tread Height (Y) of the treads where the raceway will be installed. Subtract 1-3/4" from the Y value to compensate for the height of the End Cap.
- 7 Miter the Tread Height (Y) raceways where they will meet the Tread Depth (Z) raceways. Apply a generous amount of adhesive to the underside of a clean, dry raceway base. Apply raceway base to clean, dry concrete or wood step. Secure raceway base with 3/16" x 1-1/4" flat head tapcon screws for concrete. Use wood screws for wood steps. Refer to Raceway Mitering Guidelines for additional details.
Note: Smooth out extrusion after placing to eliminate adhesive bumps and imperfections.

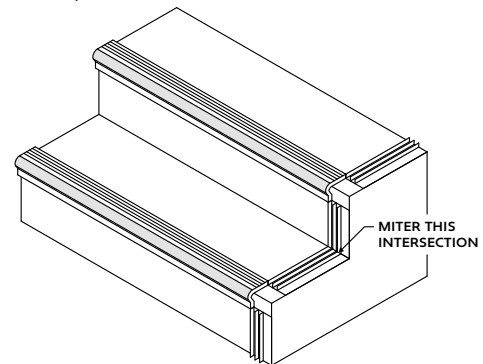

- 8 Make parallel wiring connections with blue butt-splice connectors, then lay wiring inside raceway channels.

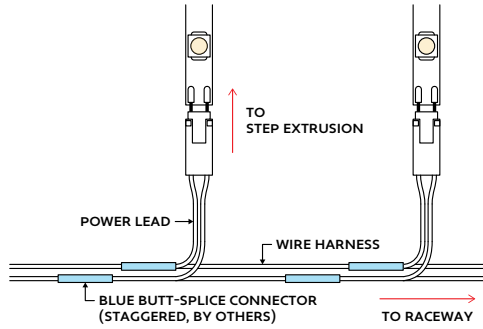

- 9 Install End Caps by using them as a template to drill pilot holes. Secure end cap with 3/16" x 1-1/4" flat head tapcon screws for concrete. Use wood screws for wood steps.
Note: Do not crush wiring with End Caps.

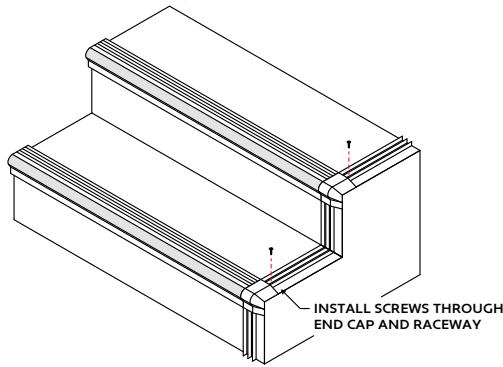

- 10 Perform a continuity test before connecting luminaire to power source.
Note: Refer to Continuity Test page for details.

- 11 Install raceway covers onto raceway bases. Snap in as shown below. Do not pinch wires with raceway cover or allow wires to be exposed.

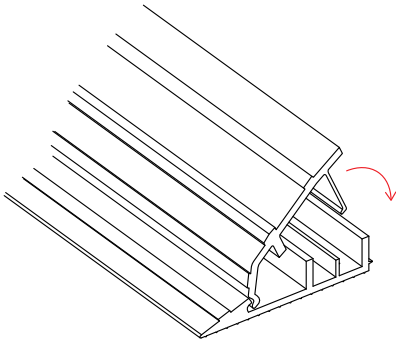

DIAGRAM OF COMPLETE ASSEMBLY

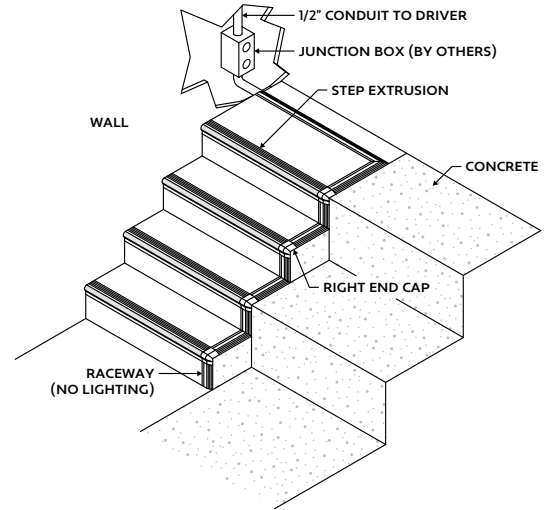
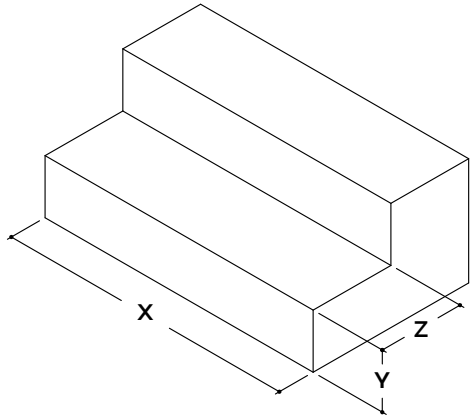

DIAGRAM OF STEPS



X: Tread Width
Y: Tread Height
Z: Tread Depth

1 Measure the Tread Width (X) of the treads where step extrusion will be installed. Subtract 2-1/2" from the X value to compensate for the width of 1 End Cap.

2 If applicable, cut up to 2-1/2" off both ends of extrusion to create space for the End Caps. Place lighting bullnose down, then measure from end of extrusion and mark a cut line. Slowly cut with a miter saw to prevent tearing or rough edges.
Note: Do not cut lightstrip or wiring.

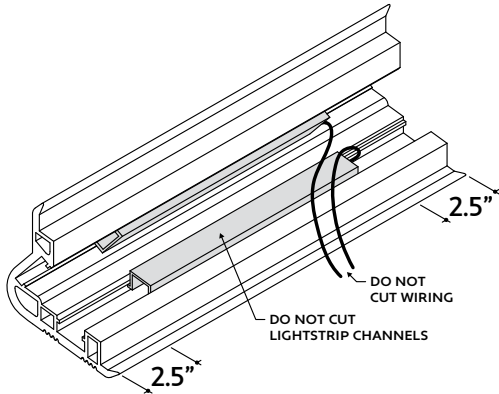

3 Apply a generous amount of adhesive to the underside of a clean, dry step extrusion. Apply step extrusion to clean, dry concrete or wood step free of dust and debris.
Note: Smooth out extrusion after placing to eliminate adhesive bumps and imperfections.

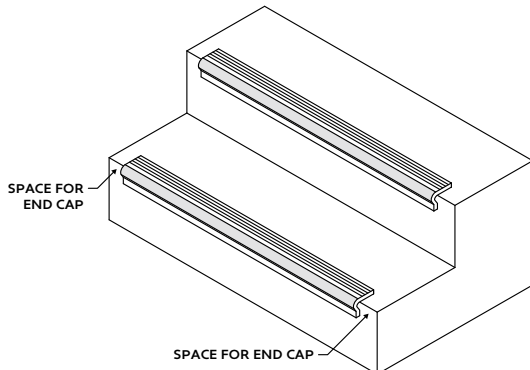

4 Measure the Tread Depth (Z) of the treads where the raceway will be installed. Subtract 2" from the Z value to compensate for the depth of the End Cap.

5 Miter the Tread Depth (Z) raceways where they will meet the Tread Height (Y) raceways. Apply a generous amount of adhesive to the underside of a clean, dry raceway base. Apply raceway base to clean, dry concrete or wood step. Secure raceway base with 3/16" x 1-1/4" flat head tapcon screws for concrete. Use wood screws for wood steps. Refer to Raceway Mitering Guidelines for additional details.
Note: Smooth out extrusion after placing to eliminate adhesive bumps and imperfections.

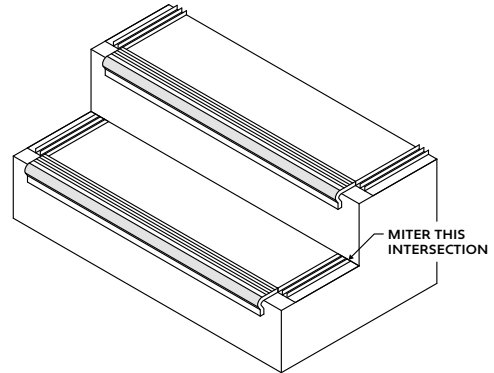

6 Measure the Tread Height (Y) of the treads where the raceway will be installed. Subtract 1-3/4" from the Y value to compensate for the height of the End Cap.

7 Miter the Tread Height (Y) raceways where they will meet the Tread Depth (Z) raceways. Apply a generous amount of adhesive to the underside of a clean, dry raceway base. Apply raceway base to clean, dry concrete or wood step. Secure raceway base with 3/16" x 1-1/4" flat head tapcon screws for concrete. Use wood screws for wood steps. Refer to Raceway Mitering Guidelines for additional details.
Note: Smooth out extrusion after placing to eliminate adhesive bumps and imperfections.

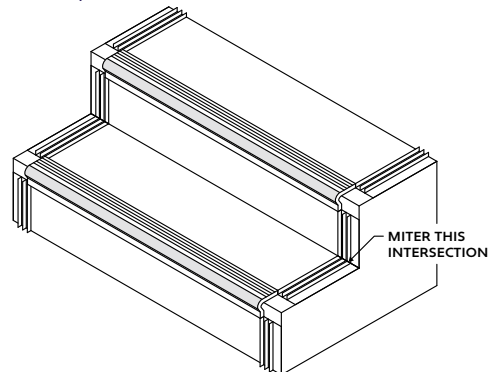

- 8 Make parallel wiring connections with blue butt-splice connectors, then lay wiring inside raceway channels.

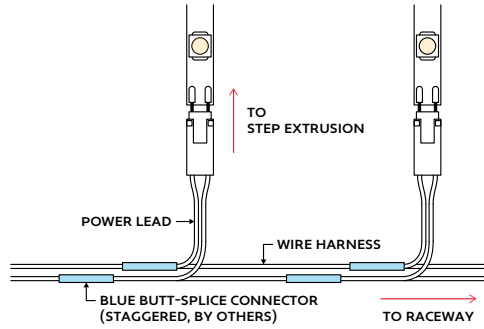

- 9 Install End Caps by using them as a template to drill pilot holes. Secure end cap with 3/16" x 1-1/4" flat head tapcon screws for concrete. Use wood screws for wood steps.
Note: Do not crush wiring with End Caps.

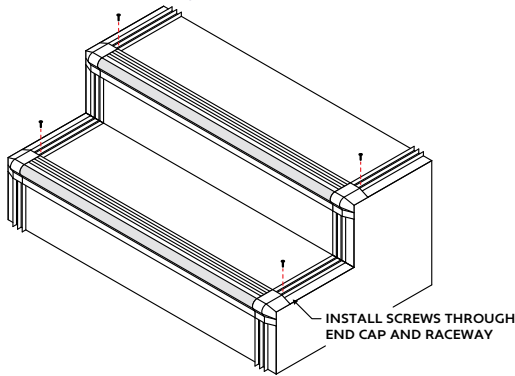

- 10 Perform a continuity test before connecting luminaire to power source.
Note: Refer to Continuity Test page for details.
- 11 Install raceway covers onto raceway bases. Snap in as shown below. Do not pinch wires with raceway cover or allow wires to be exposed.

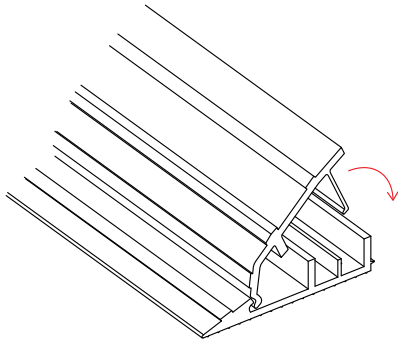
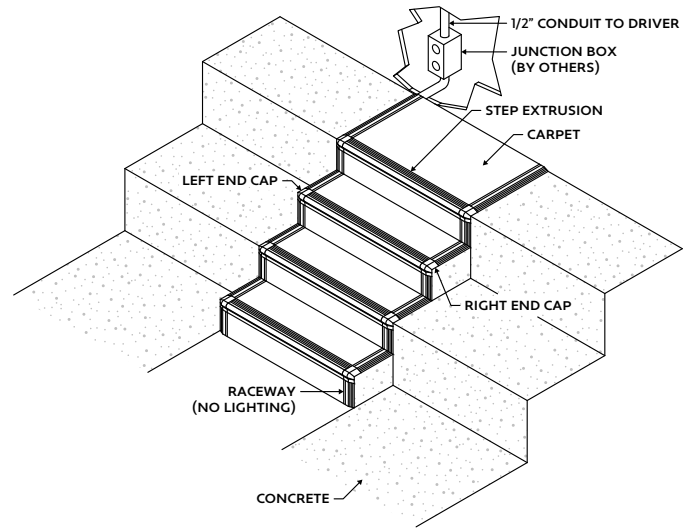

DIAGRAM OF COMPLETE ASSEMBLY



EXAMPLE: 90° MITER

Miter cuts are only to be performed on unassembled dry location products. Do not attempt to modify wet location products.

- 1 Measure area where mitered segments will be installed. Cut extrusion and lens to size +1".
Example: 7'8" extrusion to meet 1'5" extrusion. Cut extrusions to 7'9" and 1'6"
Note: Plan your cuts so that lens will always overlap where two extrusions meet. Overlapping lenses helps keep extrusions in line and prevents light leaks.

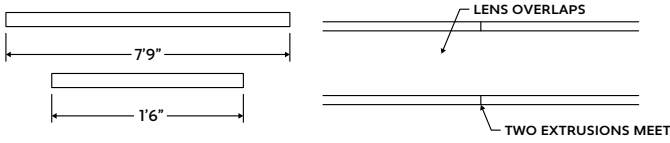

- 2 Measure angle where fixture will be mitered. Use an angle finder to determine exact angle.
Example: 90° Angle

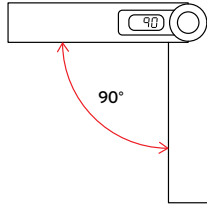

- 3 Divide measured angle by 2 ($90^\circ \div 2 = 45^\circ$). Set miter saw to 45° and cut the end of each extrusion and lens where they will intersect. Verify the miter closes properly and fits in area, then trim excess extrusion on the end without the miter to exact size.

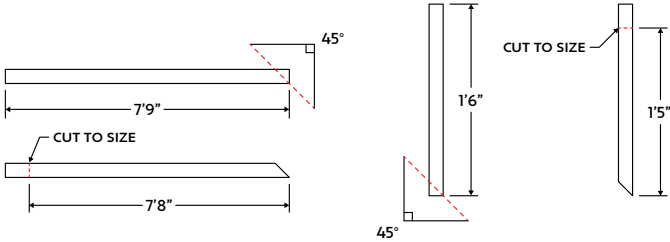

- 4 Use a small segment of wire to solder lightstrips between mitered extrusions. Do not bend lightstrip to turn corner. Refer to application guidelines for soldering steps.

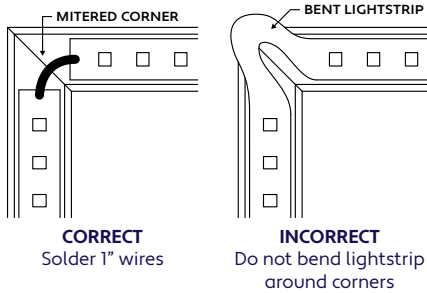

EXAMPLE: 135° MITER

- 1 Measure area where mitered segments will be installed. Cut extrusion and lens to size +1".
Example: 7'8" extrusion to meet 1'5" extrusion. Cut extrusions to 7'9" and 1'6"
Note: Plan your cuts so that lens will always overlap where two extrusions meet. Overlapping lenses helps keep extrusions in line and prevents light leaks.

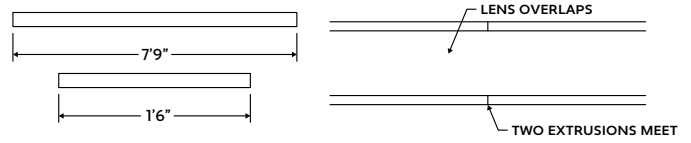

- 2 Measure angle where fixture will be mitered. Use an angle finder to determine exact angle.
Example: 135° Angle

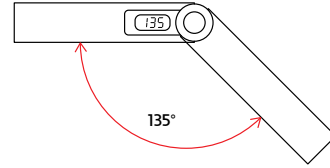

- 3 Divide measured angle by 2 ($135^\circ \div 2 = 67.5^\circ$). Set miter saw to 67.5° and cut the end of each extrusion and lens where they will intersect. Verify the miter closes properly and fits in area, then trim excess extrusion on the end without the miter to exact size.

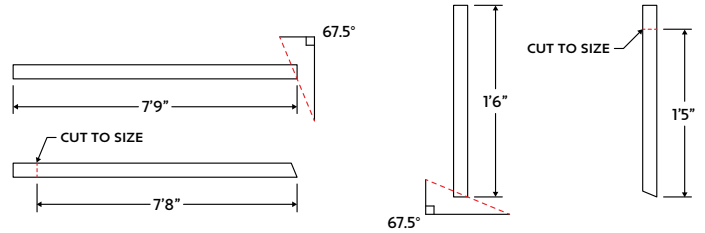

- 4 Use a small segment of wire to solder lightstrips between mitered extrusions. Do not bend lightstrip to turn corner. Refer to application guidelines for soldering steps.

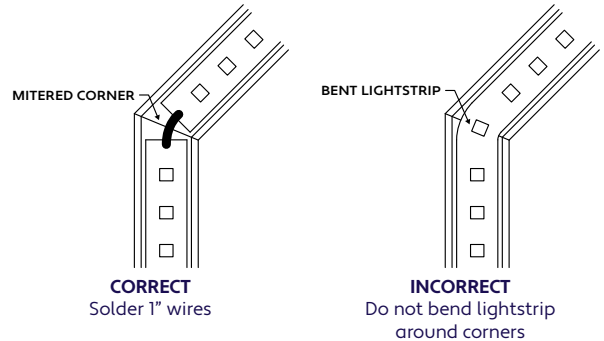

- 1 Measure Tread from end of End Cap to riser.
Example: 10"
Measure Riser from bottom of End Cap to Tread.
Example: 5"
Cut Raceway extrusions to size +1".
Example: 11", 6"

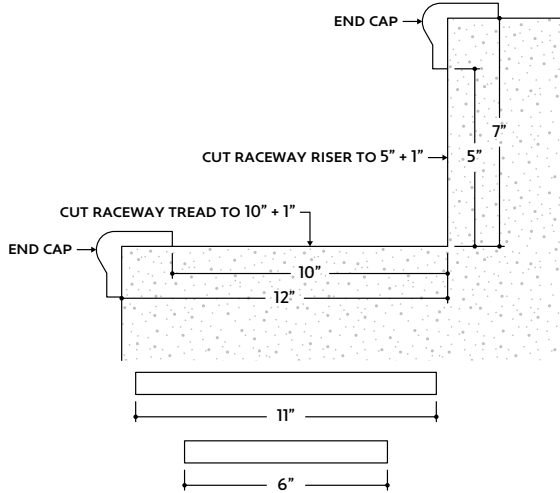

- 2 Measure angle where raceway will be mitered. Do not assume the angle, as it may deviate from 90°. **Note:** Use an angle finder to determine exact angle.
Example: 90° Angle

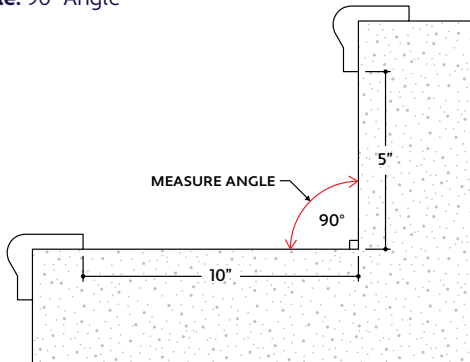

- 3 Divide measured angle by 2 ($90^\circ / 2 = 45^\circ$). Set miter saw to this angle and cut the ends of raceway extrusions where they will intersect. Trim excess raceway on opposite end to size.

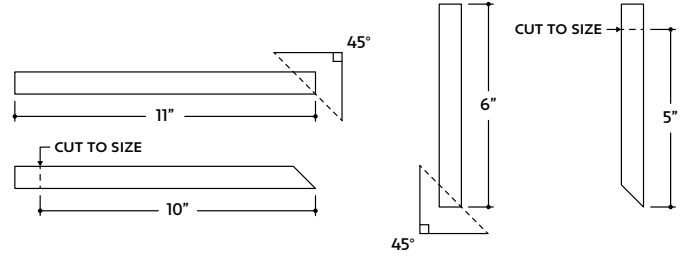

- 4 Install raceway extrusions using the steps from Single Side Mounting or Dual Side Mounting, depending on your application.

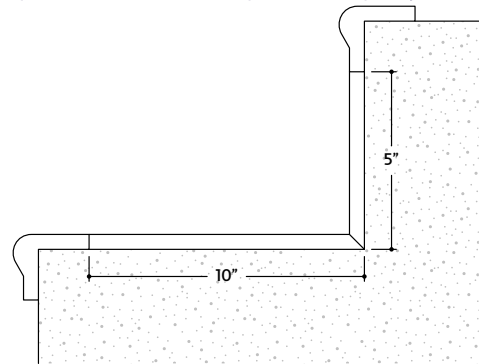

TROUBLESHOOTING TIPS

- Do not reset the breaker multiple times.
- If the unit is overloaded, the breaker will trip, shutting off the driver and lighting.
- If the breaker reset button has been held down by hand or any type of pressure, such as duct tape, or if the breaker has been reset multiple times without troubleshooting, the unit will:
 - Burn the driver bobbin.
 - Burn the thermal or magnetic breaker.
 - Burn the driver lead wires due to high amperage caused by overload.
 - Short circuit in line which will not allow the breaker to reset.
 - Damage the lighting.

- 1 Turn off power before beginning. Check for any twisting or damage to the circuit in the LED lightstrip. If there is excessive damage and the circuit is broken, the lightstrip must be replaced.

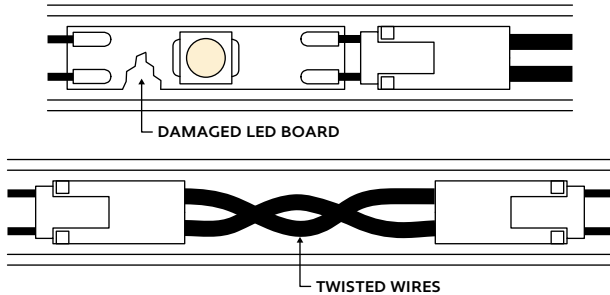

- 2 Check for metal particles or other foreign objects causing the short.

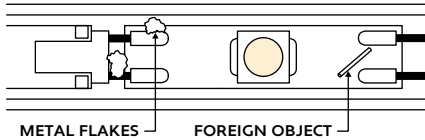

- 3 Check to make sure cuts in the lightstrip are clean and not frayed, causing positive and negative copper conductors to touch.

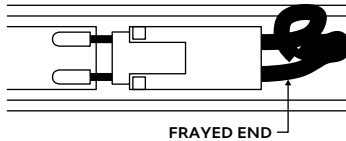

- 4 Ensure the run is not too long for the extrusion and excess wire or lightstrip is not overlapping or hanging from the end.

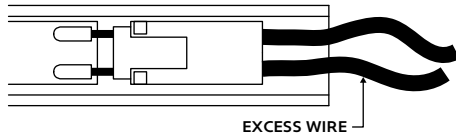

- 5 Ensure conductors are not making contact with extrusion.

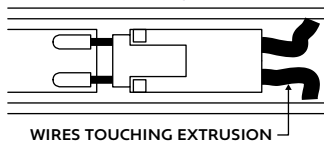

CONTINUITY TEST

A continuity test is performed to determine if electricity can pass through two points on an electrical circuit. This helps identify shorts or malfunctions in the line or luminaire. Use a multimeter or continuity tester to perform the steps below.

- Always perform a continuity test before connecting to power source.
- Malfunctions are not always as obvious as the lights not turning on.
- A short or malfunction in the line or luminaire will cause damage over time, irreparably damaging the lighting and voiding warranty.

EXAMPLE OF MULTIMETER (BY OTHERS)

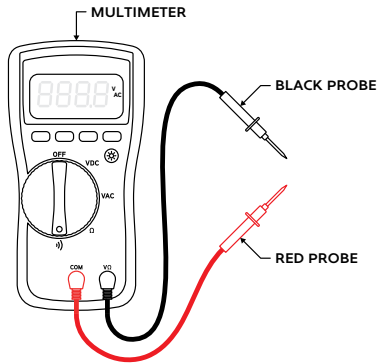

- 1 Turn off power before beginning. Verify power is off by using a non-contact circuit tester (by others). Touch the probe of the tester to the positive wire of the power source. The tester will light up if an electrical current is detected.
- 2 Setup your multimeter tester (by others). First, insert the black probe lead into the COM jack, then insert the red probe lead into the VΩ jack.

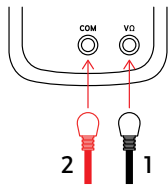

- 3 Verify multimeter is functional by touching probes together. The multimeter should beep, flash, or read 0Ω (ohms) of resistance.
- 4 Touch the red probe to the positive (+) wire and the black probe to the negative (-) wire of the luminaire. If a conductive path is formed between the positive and negative wires, the multimeter will beep, flash, or read 0Ω (ohms) of resistance. Troubleshoot to identify the malfunction in the line. If there is no conductive path formed, the multimeter will not show any feedback.

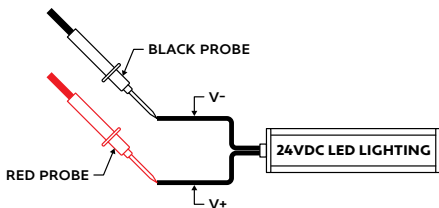

- 5 Touch the red probe to the luminaire extrusion and the black probe to the positive (+) wire. If a conductive path is formed between the extrusion and the positive wire, the multimeter will beep, flash, or read 0Ω (ohms). Troubleshoot to identify the malfunction in the line. If there is no conductive path, the multimeter will not show any feedback.

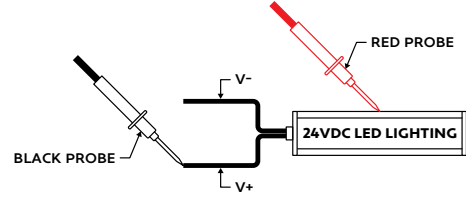

- 6 Touch the red probe to the luminaire extrusion and the black probe to the negative (-) wire. If a conductive path is formed between the extrusion and the negative wire, the multimeter will beep, flash, or read 0Ω (ohms). Troubleshoot to identify the malfunction in the line. If there is no conductive path, the multimeter will not show any feedback.

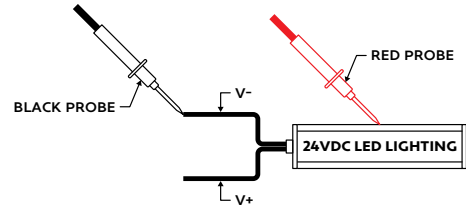

- 7 Set multimeter to DC voltage and test power source. Confirm the correct voltage before connecting luminaire to power source. If the voltage reading is more than 1 volt greater than the marked output voltage, there is a problem with the power source or driver.
- 8 Connect luminaire to power source via power connector. If LEDs do not turn on, flip the polarity (+/-) or power source connection to power connector.